

DRAWWIRE SENSOR



SX120 / SX80 / SX50

Key-Features:

- Ranges 50...6000 mm
- Analogue - Digital - Absolute - Bus
- Linearity up to 0.02 %
- Protection class up to IP67
- High dynamics
- High EMC-grade
- Customized versions available

Contents:

<i>Introduction - Applications</i>	<i>....2</i>
<i>Options</i>	<i>....3</i>
<i>SX50 up to 1250 mm</i>	<i>....4</i>
<i>SX80 up to 3000 mm</i>	<i>....6</i>
<i>SX120 up to 6000 mm</i>	<i>....8</i>
<i>Analog output</i>	<i>..10</i>
<i>Digital output</i>	<i>..11</i>
<i>Absolute output</i>	<i>..12</i>
<i>Accessories</i>	<i>..13</i>
<i>Installation - warning notices</i>	<i>..14</i>
<i>Order code</i>	<i>..15</i>

28.01.11

INTRODUCTION

WayCon Positionsmesstechnik GmbH is a manufacturer of high quality draw wire position transducers for industrial use. Due to its small overall size, its short assembly time and its possible customization, the SX sensor technology is a cost-effective and flexible solution for a wide range of industrial applications. The dynamics of the draw wire transducer allows a high motion speed and acceleration of the measuring target. Its rugged design and high quality makes applications in harsh industrial environments possible. Special instruments are available with mounting service of encoder on site, as well as customised versions of housing.

Sensor principle:

A constant spring force coils the measuring rope accurately, single-layered on an ultralight rope capstan, so that its linear motion is converted into rotation. The sensor element (encoder) provides the output signal required.

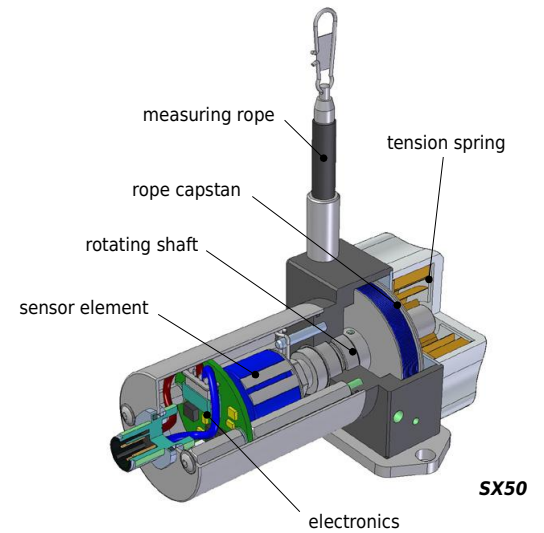

OUTLINE

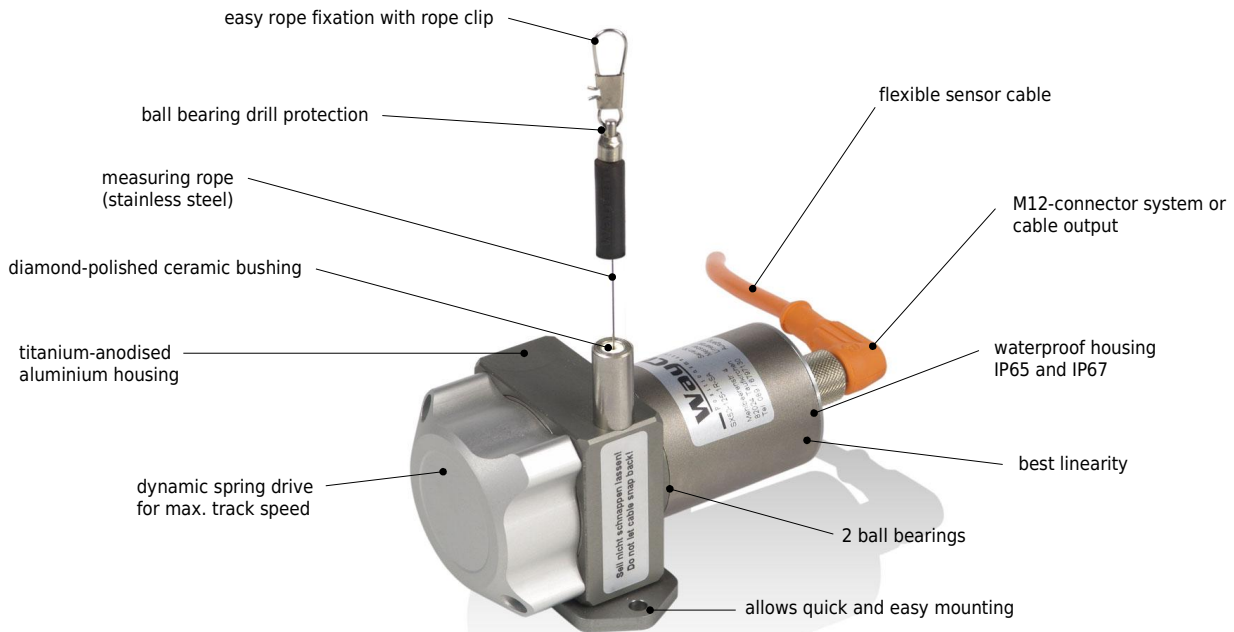

APPLICATIONS

- lifting tables and platforms
- suspension of vehicles
- positioning of fork-lifts
- level control system
- portal frames and gantry cranes
- medical technology
- lifting and rescue technology
- x-y-axis positioning
- pneumatic cylinder
- hydraulic cylinder and press slit
- injection moulding machine
- crash-tests
- air frame load testing
- auto body/ carriage deformation
- robot application
- property management
- linear guides
- pipe displacement

OPTIONS

HG

A reinforced spring drive provides a greater rope tension and allows a higher rope acceleration. Please note the different dimensions of the housing and the higher traction of the rope. This option is only available for the series SX50.

CO / ICP

CO: By the use of a special technology all components of the housing and the inner mechanics become HARTCOAT® coated. This coating is a hartanodic oxidation that protects the sensor from corrosion by aggressive media (e. g. sea water) with a hard ceramics-like layer.

ICP: This version combines the options CO (HARTCOAT®-coating) and IP67 (protection class IP67). In addition, a increased corrosive protection is achieved by the use of special components.

IN

The analog signal of the sensor is increasing by extracting the rope (standard). Option IN inverts the signal, i. e. the signal of the sensor declines by extracting the rope.

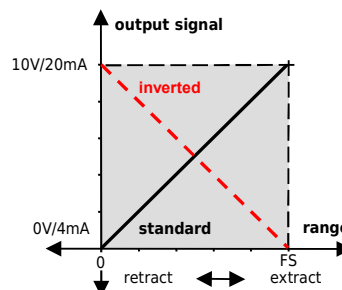

L25 / L10 / L05 / L02

Improved linearity on 0.25 %, 0.10 % or 0.05 % of measuring range. Resolution, repeatability and sensibility remain unchanged.

L02: Improved linearity on 0.02 % of measuring range. Resolution, repeatability and sensibility remain unchanged. This option is only available for incremental sensors.

IP67

Use option IP67, if sensor is fully immersed in water (temporarily). Note that with this option there may occur a light hysteresis in the output signal due to the special sealing. The max. acceleration is reduced to 60 % of the specified value.

S1 / S2 / S3

Optional rope outlet (see diagram)

- S1 rope outlet on up
- S2 rope outlet on down
- S3 rope outlet at bottom

(S2/ S3 with different mounting plate)

K1 / K2

Optional cable/ connector orientation for sensors with digital output/ encoder (see diagram)

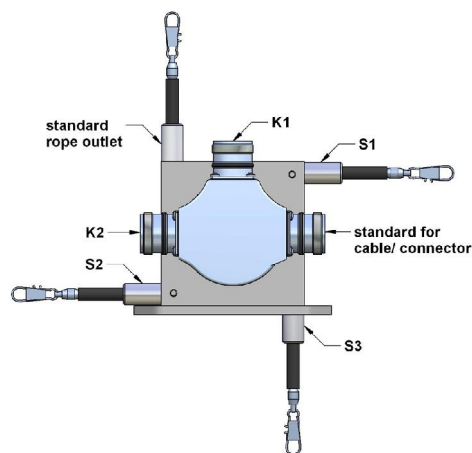

M4 rope fixation

Optional, pivoted rope fixation with screw thread M4, length 22 mm. Ideal for attachment to through holes or thread holes M4.

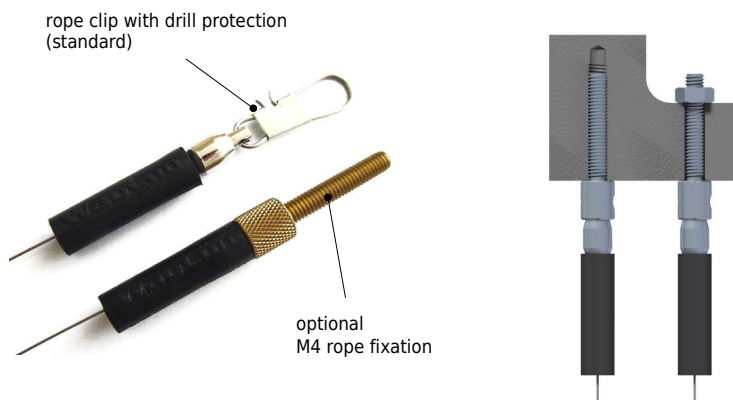

SERIES SX50

**max. 1250 mm
analog/ digital
digital-absolute
bus systems**



output	analog	digital output / digital-absolute / bus systems
sensor element	potentiometer/ 0...10 V/ 4...20 mA (page 10)	A/B-pulse, 90° phase-delayed (page 11-12)
connection	M12-connector or cable output	connector or cable output
protection class	IP65, optional IP67	IP65, optional IP67
humidity	max. 90 % relative, not condensating	max. 90 % relative, not condensating
life time	approx. 2 million full cycles	approx. 2 million full cycles
weight	approx. 330 g	approx. 330 g
housing	aluminium, titanium-grey anodised	aluminium, titanium-grey anodised

Technical data - analog output

measurement range [mm] *	50	75	100	125	150	225	250	300	375	500	625	750	1000	1250
linearity [%]	0.50	0.50	0.50	0.50	0.15	0.15	0.15	0.15	0.15	0.15	0.15	0.10	0.10	0.10
linearity optional [%]	0.25	0.25	0.25	0.25	0.10	0.10	0.10	0.10	0.10	0.10	0.10	0.05	0.05	0.05
linearity optional [%]	0.10**	0.10**	0.10**	0.10**	-	-	-	-	-	-	-	-	-	-

Technical data - digital output

measurement range [mm] *	500	750	1250				
linearity [%]	0.05, independent from measurement range						
linearity optional [%]	0.02, independent from measurement range						
available resolution [pulses/ mm]	1	4	8	12	16	29	60 ***
Z-pulse-distance [mm]	125						

* other measurement ranges on request

** special version with unprotected potentiometer, protection class IP40 (please ask for technical drawing)

*** special version (please ask for price and technical drawing)

Mechanical data

range [mm]	rope tension		velocity	acceleration*	rope tension HG		acceleration HG*
	F _{min} [N]	F _{max} [N]	V _{max} [m/s]	a _{max} [m/s ²]	F _{min} [N]	F _{max} [N]	a _{max} [m/s ²]
50	6.8	6.8	8.0	200	13.2	13.7	400
75	3.9	4.4	8.0	200	7.3	7.9	400
100	3.4	3.4	8.0	200	5.9	6.4	400
125	4.9	5.4	10.0	300	6.9	7.9	500
150	6.8	7.9	8.0	200	13.2	13.7	400
225	3.9	4.6	8.0	200	7.3	8.3	400
250	6.8	7.9	8.0	200	13.2	13.7	400
300	3.2	4.0	8.0	200	5.9	6.7	400
375	4.7	5.4	10.0	300	6.9	7.9	500
500	3.4	4.0	8.0	200	5.9	6.9	400
625	4.4	5.4	10.0	300	6.9	7.9	500
750	3.9	5.4	8.0	200	7.3	9.8	400
1000	3.1	4.0	8.0	200	5.9	7.9	400
1250	4.1	5.4	10.0	300	6.9	8.3	500

* reduced to 60 % with option IP67

TECHNICAL DRAWING SX50

analog output

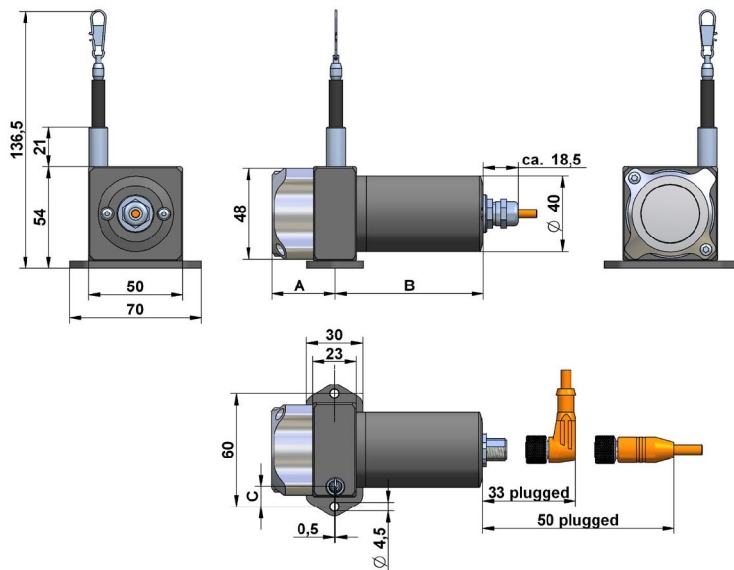

output	B
potentiometer	65
10V / 420A	78.5

range	option	A	C
50 / 150 / 250 mm	Standard	26.5	21.3
75 / 225 / 750 mm	Standard	26.5	17
100 / 300 / 500 / 1000 mm	Standard	26.5	12.75
125 / 375 / 625 / 1250 mm	Standard	33.5	10.3
50 / 150 / 250 mm	HG	33.5	21.3
75 / 225 / 750 mm	HG	33.5	17
100 / 300 / 500 / 1000 mm	HG	33.5	12.75
125 / 375 / 625 / 1250 mm	HG	46.5	10.3

digital output incremental

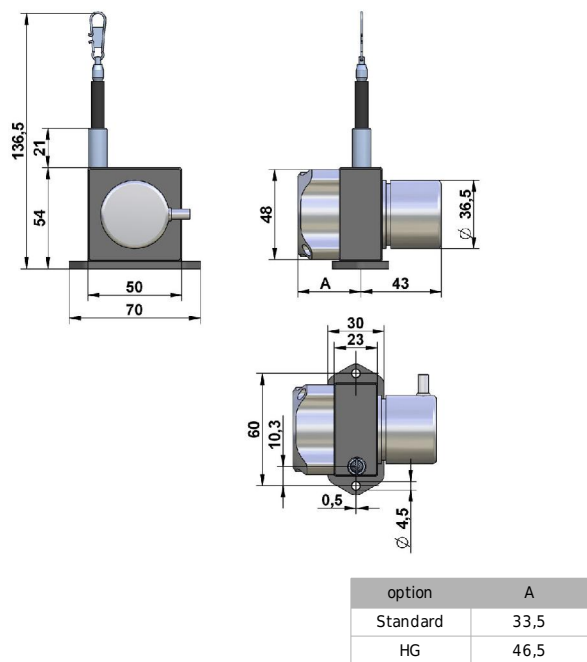

digital-absolute: SSI, CAN

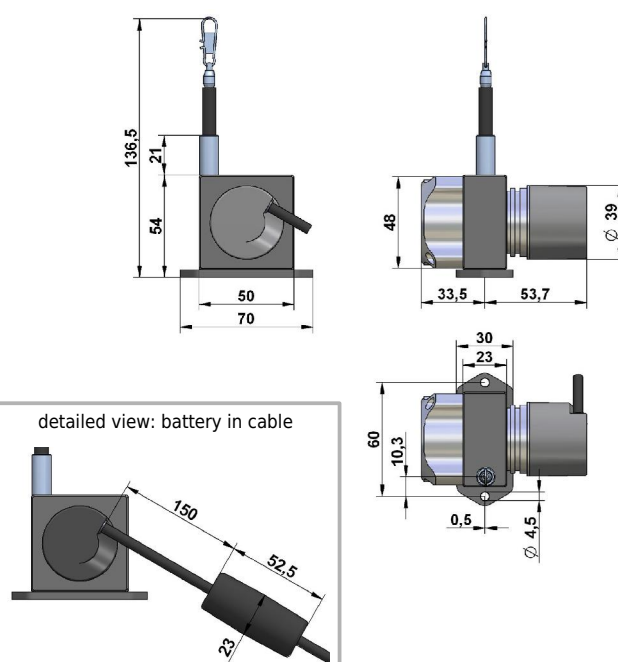

mounting

The sensor can be installed by using the mounting plate (see drawing above).
By disassembling the mounting plate, there are 4 threads (2 x M3, 2 x M5) in the sensor housing for installing.

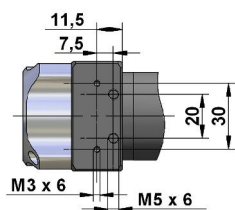

Sensors with option rope outlet S2 and S3 have a different base plate.

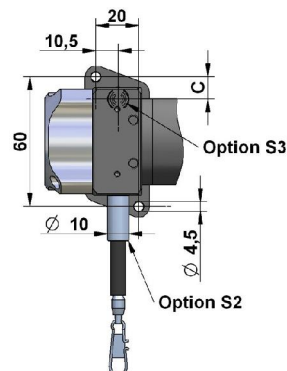

SERIES SX80

max. 3000 mm
analog/ digital
digital-absolute
bus systems



output	analog	digital output / digital-absolute / bus systems
	potentiometer/ 0...10 V/ 4...20 mA (page 10)	A/B-pulse, 90° phase-delayed (page 11-12)
sensor element	hybrid potentiometer	incremental encoder/ optical code disc
connection	M12-connector or cable output	connector or cable output
protection class	IP65, optional IP67	IP65, optional IP67
humidity	max. 90 % relative, not condensating	max. 90 % relative, not condensating
life time	approx. 2 million full cycles	approx. 2 million full cycles
weight	approx. 750 g	approx. 750 g
housing	aluminium, titanium-grey anodised	aluminium, titanium-grey anodised

Technical data - analogue output

measurement range [mm] *	1000	1500	2000	2500	3000
linearity [%]	0.15	0.15	0.10	0.10	0.10
linearity optional [%]	0.10	0.10	0.05	0.05	0.05

Technical data - digital output

measurement range [mm] *	1000	1500	2000	2500	3000	
linearity [%]	0,05, independent from measurement range					
linearity optional [%]	0,02, independent from measurement range					
available resolution [pulses/ mm]	0.5	1	2,5	5	10	25
Z-pulse-distance [mm]	200					

* other measurement ranges on request

Mechanical data

range [mm]	rope tension		velocity	acceleration*
	F_{min} [N]	F_{max} [N]	v_{max} [m/s]	a_{max} [m/s ²]
1000	6.9	8.3	10	140
1500	6.9	8.8	10	140
2000	6.4	7.8	10	140
2500	6.9	8.8	10	140
3000	6.9	9.8	10	140

* reduced to 60 % with option IP67

TECHNICAL DRAWING SX80

analog output

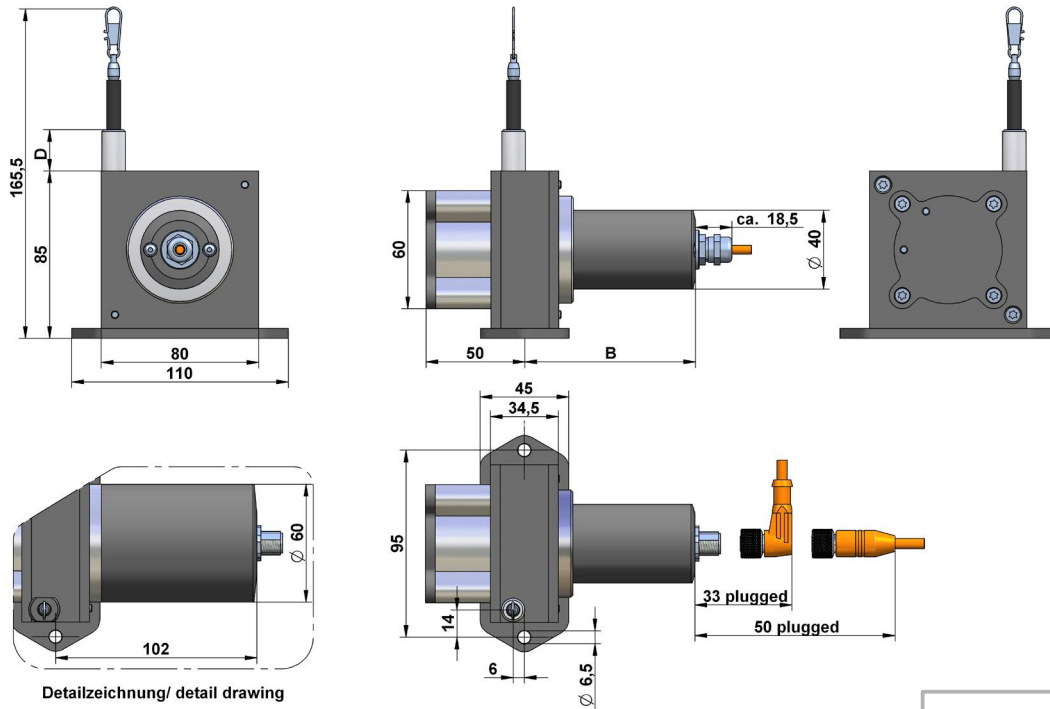

Detailzeichnung/ detail drawing

range	output	B	D
1000/2000 mm	potentiometer	74	21
1000/2000 mm	10V / 420A	87,5	21
1500 mm	see detailed view		21
2500/3000 mm	see detailed view		35

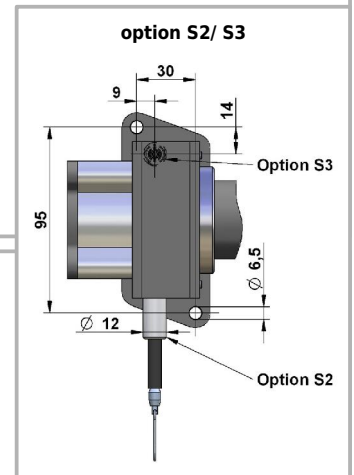

digital output

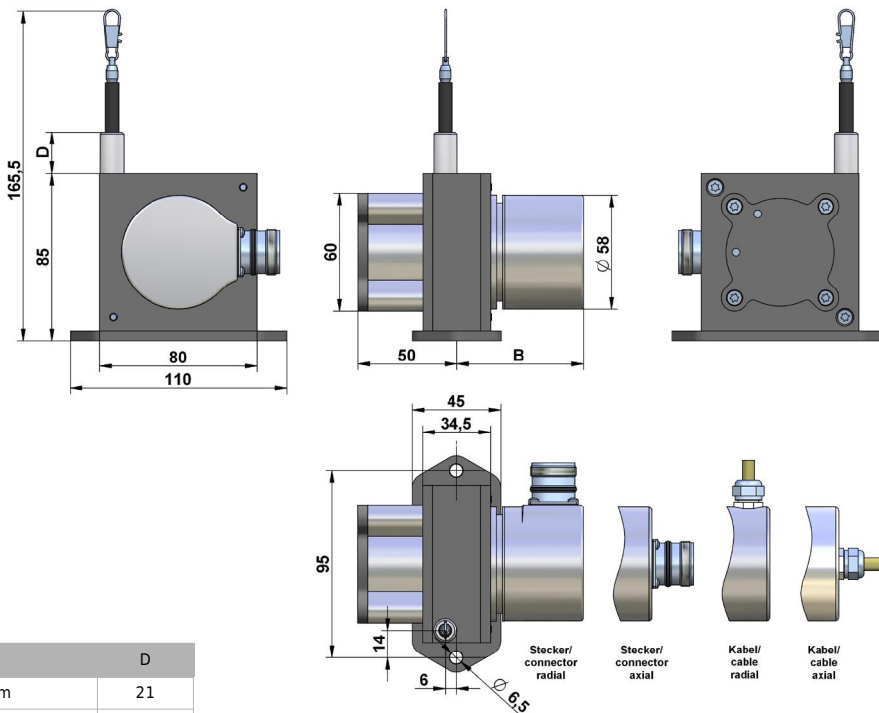

range	D
1000/1500/2000 mm	21
2500/3000 mm	35

option	B
cable/ connector axial, cable radial	54,3
connector radial	64,3

SERIES SX120

**max. 6000 mm
analog/ digital
digital-absolute
bus systems**

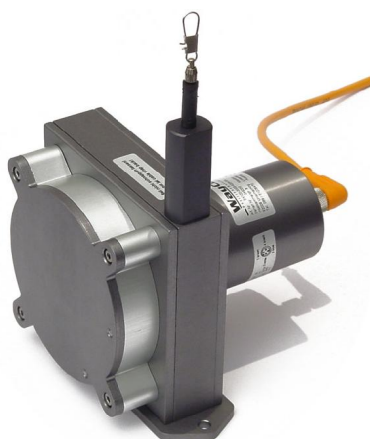

output	analog potentiometer/ 0...10 V/ 4...20 mA (page 10)	digital output / digital-absolute / bus systems A/B-pulse, 90° phase-delayed (page 11-12)
sensor element	hybrid potentiometer	incremental encoder/ optical code disc
connection	M12-connector or cable output	connector or cable output
protection class	IP65, optional IP67	IP65, optional IP67
humidity	max. 90 % relative, not condensating	max. 90 % relative, not condensating
weight	approx. 1625 g	approx. 1625 g
housing	aluminium, titanium-grey anodised	aluminium, titanium-grey anodised

Technical data - analogue output

measurement range [mm] *	3125	4000	5000	6000
linearity [%]	0.10	0.10	0.10	0.10
linearity optional [%]	0.05	0.05	0.05	0.05

Technical data - digital output

measurement range [mm] *	3125	4000	5000	6000	
linearity [%]	0,05, independent from measurement range				
linearity optional [%]	0,02, independent from measurement range				
available resolution [pulses/ mm]	0.3	1.6	3.1	6.3	16
Z-pulse-distance [mm]	317.68				

* other measurement ranges on request

Mechanical data

range [mm]	rope tension		velocity	acceleration*
	F _{min} [N]	F _{max} [N]	V _{max} [m/s]	a _{max} [m/s ²]
3125	8.8	11.3	10	140
4000	8.8	11.8	10	140
5000	8.8	12.0	10	140
6000	8.8	12.3	10	140

* reduced to 60 % with option IP67

TECHNICAL DRAWING SX120

analog output

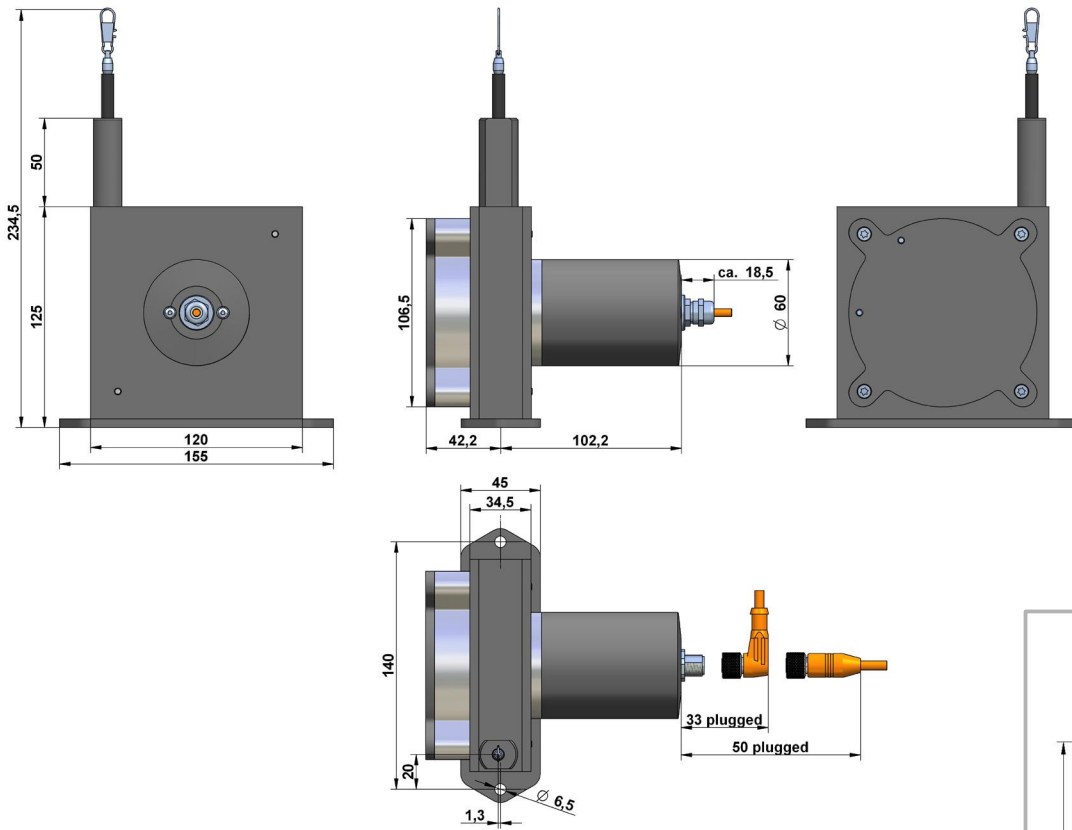

digital output

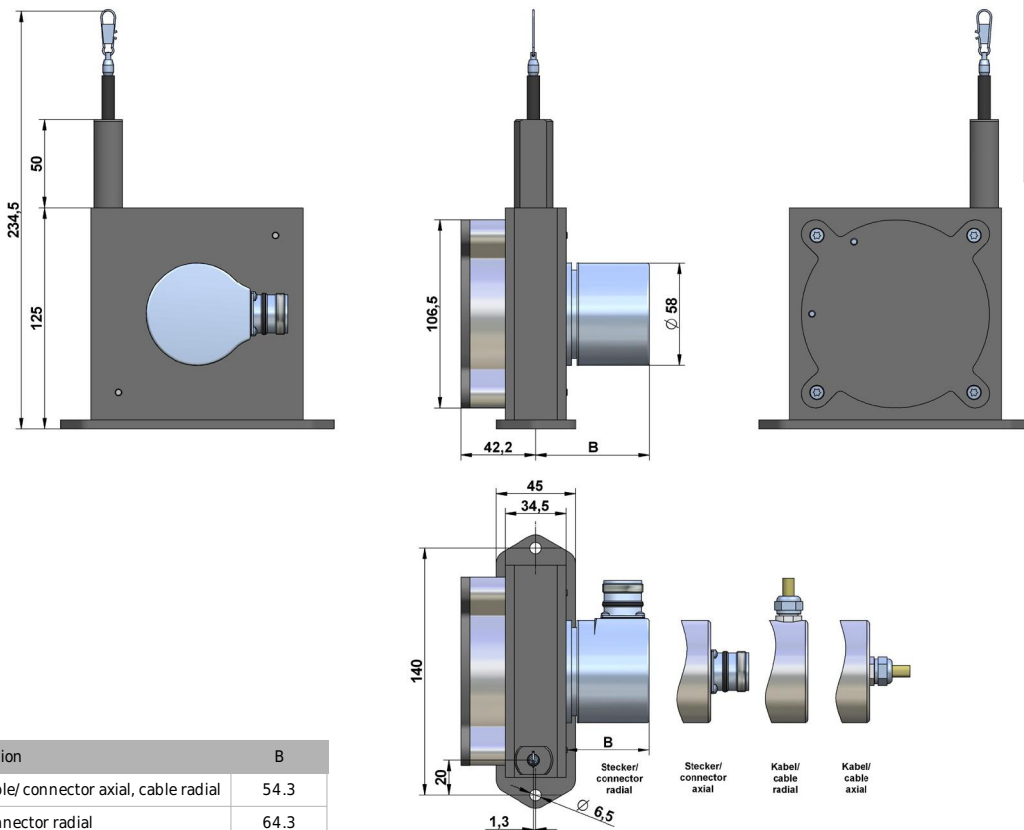

option	B
cable/ connector axial, cable radial	54.3
connector radial	64.3

ANALOG OUTPUT

Potentiometer (voltage divider)

output	1 kOhm
supply voltage	max. 30 V
recommended cursor current	< 1 μ A
noise	depending on supply
working temperature	-20...+85 °C
temperature coefficient	\pm 0,0025 %/K

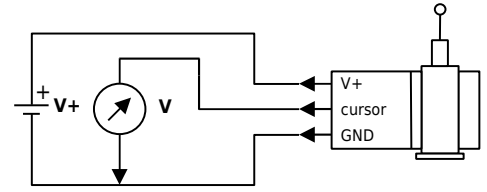

0...10 V voltage output

output	0...10 V, galvanically isolated, 4 conductors
supply voltage	12...30 VDC
max. current consumption	22.5 mA (unloaded)
output current	max. 10 mA, min. load 1 kOhm
dynamics	< 3 ms from 0...100 % and 100...0 %
noise	3 mV _{pp} typically, max. 37 mV _{pp}
inverse-polarity protection	yes, infinite
short-circuit proof	yes, permanent
working temperature	-20...+85 °C
temperature coefficient	0,0037 %/K
electromagnetic compatibility (EMC)	according to EN 61326-1:2006

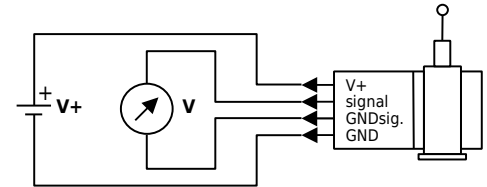

note: GNDsignal and GND may be connected in 3-wire system.

4...20 mA current output

output	4...20 mA, 2 conductors
voltage supply	12...30 VDC
output current	max. 50 mA in case of error
dynamics	< 1 ms from 0...100 % and 100...0 %
noise	0,03 mA _{pp} = 6 mV _{pp} at 200 Ohm
inverse-polarity protection	yes, infinite
working temperature	-20...+85 °C
temperature coefficient	0,0079 %/K
electromagnetic compatibility (EMC)	according to EN 61326-1:2006

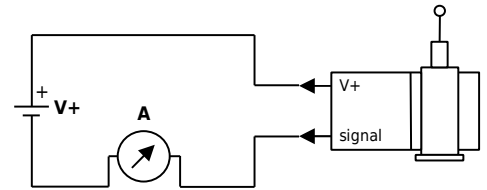

CONNECTION

cable output:

axial 2,0 metre standard, other cable length optional
 type: TPE, flexible
 diameter: \varnothing 4.5 mm
 stranded wire: 0.25 mm²
 temperature range: fixed installation -30...+85 °C, flexible installation -20...+85 °C

pin	wire colour	10 V	420 mA	1 kOhm
1	brown	V +	V +	V +
2	white	signal	n. c.	cursor
3	blue	GND	signal	GND
4	black	GND signal	n. c.	n. c.

4-pin M12 connector output (socket):

profile/ view on solder side of mating connector

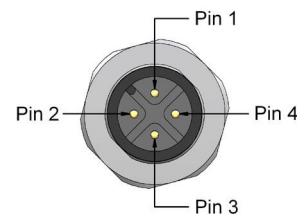

DIGITAL OUTPUT INCREMENTAL

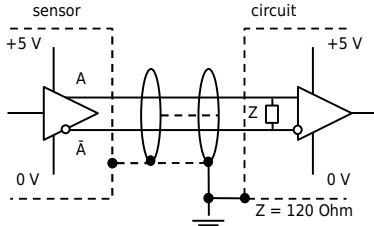
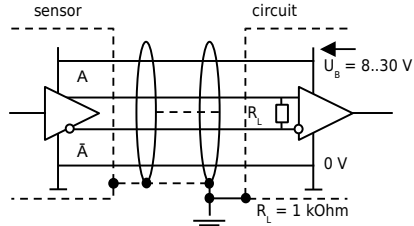
Electrical data	Linedriver L	Push Pull G
	RS422 (TTL-compatible)	
supply voltage	5 VDC, $\pm 5\%$	8...30 VDC
current consumption (no load)	typical 70 mA, max. 100 mA	typical 80 mA, max. 150 mA
max. load/ channel SX50	± 10 mA	± 30 mA
max. load/ channel SX80/ 120	± 20 mA	± 30 mA
max. pulse frequency SX50	125 kHz	100 kHz
max. pulse frequency SX80/ 120	300 kHz	300 kHz
min. signal level high	2,5 V	$U_B - 3$ V
max. signal level low	0,5 V	2,5 V
recommended circuit		
connection	connector 12-pin (counterclockwise), cable output 1,5 m	connector 12-pin (counterclockwise), cable output 1,5 m
protection class	IP65, optional IP67	IP65, optional IP67
max. cable length	up to 1000 m	up to 250 m

output signal

Pulses A and B are 90° phase-delayed (detection of direction). The Z-signal recurs with pulse distance Z and may be used as point of reference.

Diagramm shows the signal without inverted signals; timeline for return of rope.

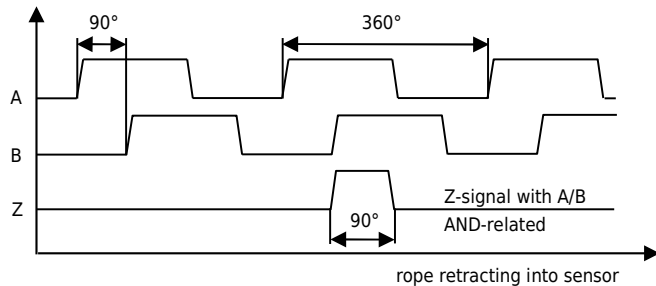

CONNECTION

Assignment

signal	0 V	U_B+	$0 V_{sens}^*$	$U_{Bsens}+^*$	A	A -	B	B -	Z	Z -	screen
12-pin connector	10	12	11	2	5	6	8	1	3	4	housing
wire colours	white	brown	black	violet	green	yellow	grey	pink	blue	red	housing

* For Linedriver L only. For long cable lengths it may occur that the operating voltage at the sensor does not suffice due to the output resistance. With the sensor lines $0V_{sens}$ and $+UB_{sens}$ the operating voltage can be checked and, if necessary, be readjusted at the input connection.

12-pin connector output (socket)

Profile/ view on solder side of mating connector (only SX80/ SX120)

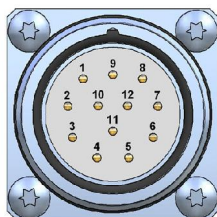

cable output

radial/ axial 1,5 meter standard
 other cable length optional
 type: UL2464/ 1061, LIYY, flexible
 outer diameter: \varnothing 6.5 mm
 stranded wire: 0.25 mm²
 temperature range: fixed installation -30...+80 °C,
 flexible installation -20...+80 °C

DIGITAL-ABSOLUTE / BUS SYSTEMS

output	Profibus-DP	CANopen	DeviceNet	EtherCAT	SSI
available for series	SX80/ 120	SX50/ 80/ 120	SX80/ 120	SX80/ 120	SX50/ 80/ 120
scalable resolution	yes	yes	yes	yes	no
standard resolution SX50 [pulses/ mm]	-	65.54	-	-	32.77
max. resolution SX50 [pulses/ mm]	-	524,29	-	-	-
standard resolution SX80 [pulses/ mm]	40.96	40.96	20.48	40.96	40.96
max. resolution SX80 [pulses/ mm]	327.68	327.68	20.48	327.68	-
standard resolution SX120 [pulses/ mm]	25.79	25.79	12.89	25.79	25.79
max. resolution SX120 [pulses/ mm]	206.3	206.3	12.89	206.3	-
supply voltage	10...30 VDC	10...30 VDC	10...30 VDC	10...30 VDC	10...30 VDC
current consumption (no load, at 24 VDC)	90 mA	65 mA	max. 290 mA	90 mA	25 mA
protection class	IP65	IP65	IP65	IP65	IP65
protection class optional	IP67	IP67	-	IP67	IP67
working temperature	-20...+80 °C	-20...+80 °C	-20...+80 °C	-20...+80 °C	-20...+80 °C

Other encoder types (supply voltage, resolution, cable/ connector output) are available on request.

TECHNICAL DRAWING (ADDITION)

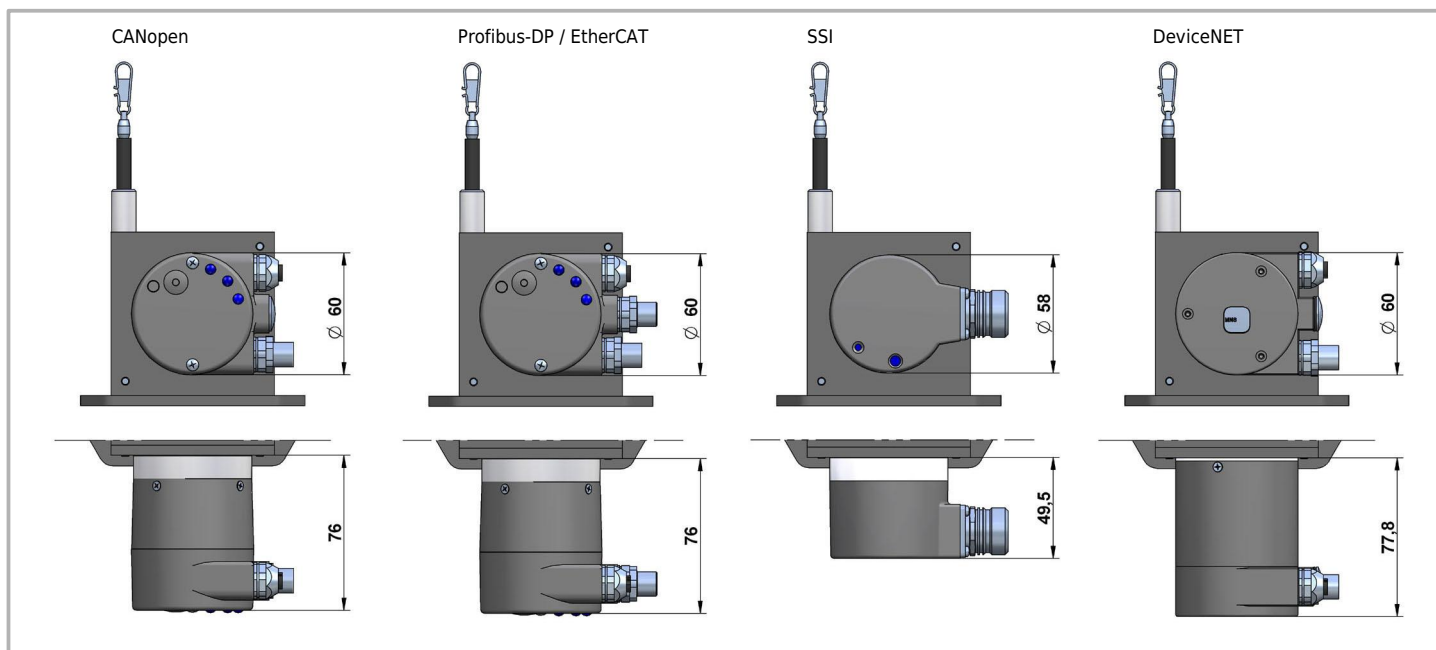

CONNECTION

encoder type	(other connection variants and protocols on request)
Profibus-DP	bus terminal cover, 3 x M12-connector (2 x male, 1 x female)
CANopen	removable bus terminal cover, 2 x M12-connector (1 x male, 1 x female)
DeviceNET	bus terminal cover, 2 x M12-connector (1 x male, 1 x female)
EtherCAT	bus terminal cover, 3 x M12-connector (1 x male, 2 x female)
SSI	12-pin M23-connector (pins counterclockwise), mating connector CON012-S

Please see encoder manual for detailed connection.

ACCESSORIES

Cable with mating connector M12 straight and angular - K4P (for analog output potentiometer/ 10V/ 420A)

cable with straight connector:		cable with angular connector:	
K4P2M-S-M12	2 m	K4P2M-SW-M12	2 m
K4P5M-S-M12	5 m	K4P5M-SW-M12	5 m
K4P10M-S-M12	10 m	K4P10M-SW-M12	10 m



Mating connector M12 straight and angular for analogue output (field attachable connector)

straight connector:	D4-G-M12-S		
angular connector:	D4-W-M12-S		
protection class:	IP67	cable diameter:	ø 3...6.5 mm
temperature range:	-25...+90 °C	conductor:	max. 0.75 mm ²
mode of connection:	screw terminals		good chemical and oil resistance



Mating connector M23 for digital output and SSI - CON012-S

M23, straight, female connector, 12-pin clockwise (fits to male, counterclockwise connector)
metal housing

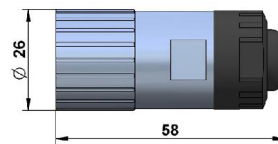

Deflection pulley - UR2

By using the deflection pulley, the rope can be looped around to e. g. measure in places that are difficult to access or to protect the sensor from inclined traction on the rope. Several pulleys may be used.

material: anodised aluminium, POM
mounting: by 2 hexagon socket or countersunk screws M6,
vertical or horizontal mounting possible.

Ball bearings with special low temperature grease and RS-sealing.

Temperature range: -40...+80 °C.

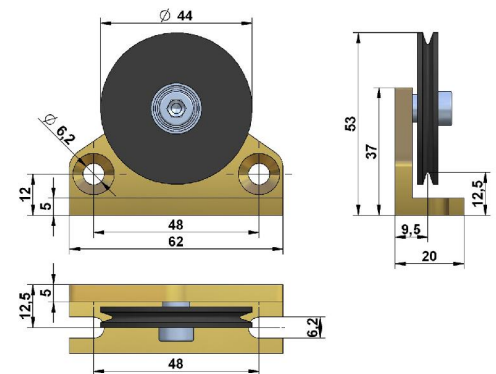
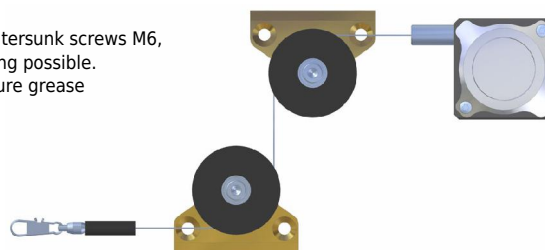

Rope extension - SV

For bridging a greater distance from the measuring target to the sensor a rope extension can be applied. The rope clip must not be guided over the deflection pulley.

Please specify the length needed in your order.
(example: rope extension of 250 mm = SV-250)



Magnetic clamp - MGG1

Use the magnetic clamp to quickly attach the rope to metallic objects without any assembly time. A rubber coating provides gentle contact (e. g. on varnished surfaces) and prevents from slipping due to vibration.

The magnet consists of a neodym core for an increased adhesive force of 260 N. The hook makes it easy to attach the rope clip (drill protection).

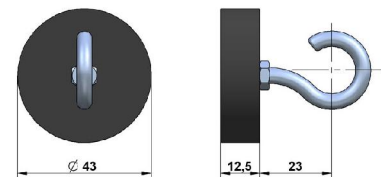

INSTALLATION

- Mount the sensor at the designated place by using the fixing holes **before** extracting the rope and **before** attaching the rope to the measuring target.
- Open the rope clip (not with set screw M4) after the sensor is fully mounted and extract the measuring rope. Hook the rope clip on the measuring object and close the bracket of the clip. For your safety put a screw driver trough the clip to extract the rope.
- Check the track of the measuring target on **collision** with the sensor housing and on **exceeding** the specified measurement range. When installing the sensor make sure that the rubber stopper does not touch the rope outlet.
- Connect the electronics according to the sensor type. When laying the cables be careful not to under-run the minimal allowed bending radius of the cable (5 x cable diameter).
- The rope must be extracted from the sensor **vertically**. The maximum variation from the vertical is 3°. Avoid carefully extracting the rope at an inclination, since the durability of the instrument would shorten considerably. If it is not possible to keep the limit of 3°, a deflection pulley has to be used.
- The measuring range/ the **zero point** begins after approximately 2 mm extracted rope. The mechanical reserve at the end of the measuring range is about 20 mm.
- When mounting outdoors protect the sensor and the rope from ice-formation at temperatures below 0 °C.
- Lay the rope preferably in corners or guarded in guidings to prevent pollution or accidental touch.
- When operating the sensor, take care **not to let** the rope **snap back** by mistake or extract the rope **over** the specified **measurement range**, as this might destroy the sensor.
- **Maintenance:** These instruments are maintenance-free. If however, the rope is soiled due to adverse environmental conditions, it should be cleaned with a cloth drenched in resin-free machine oil.



WARNING NOTICES

- Don't let the rope snap back. If the rope is retracted freely, this may lead to injuries (whiplash effect) and the instrument may be damaged. Caution when unhooking and retracting the rope into the sensor.
- Never exceed the specified measurement range when extracting the rope!
- Don't try to open the instrument. The stored energy of the spring drive may lead to injuries when being mishandled.
- Don't touch the rope when operating the sensor.
- Avoid guiding the rope over edges or corners. Use a deflection pulley instead.
- Don't operate the sensor if the rope is buckled or damaged. A ripping of the rope may lead to injuries or damaging the sensor.



ORDER CODE ANALOG OUTPUT

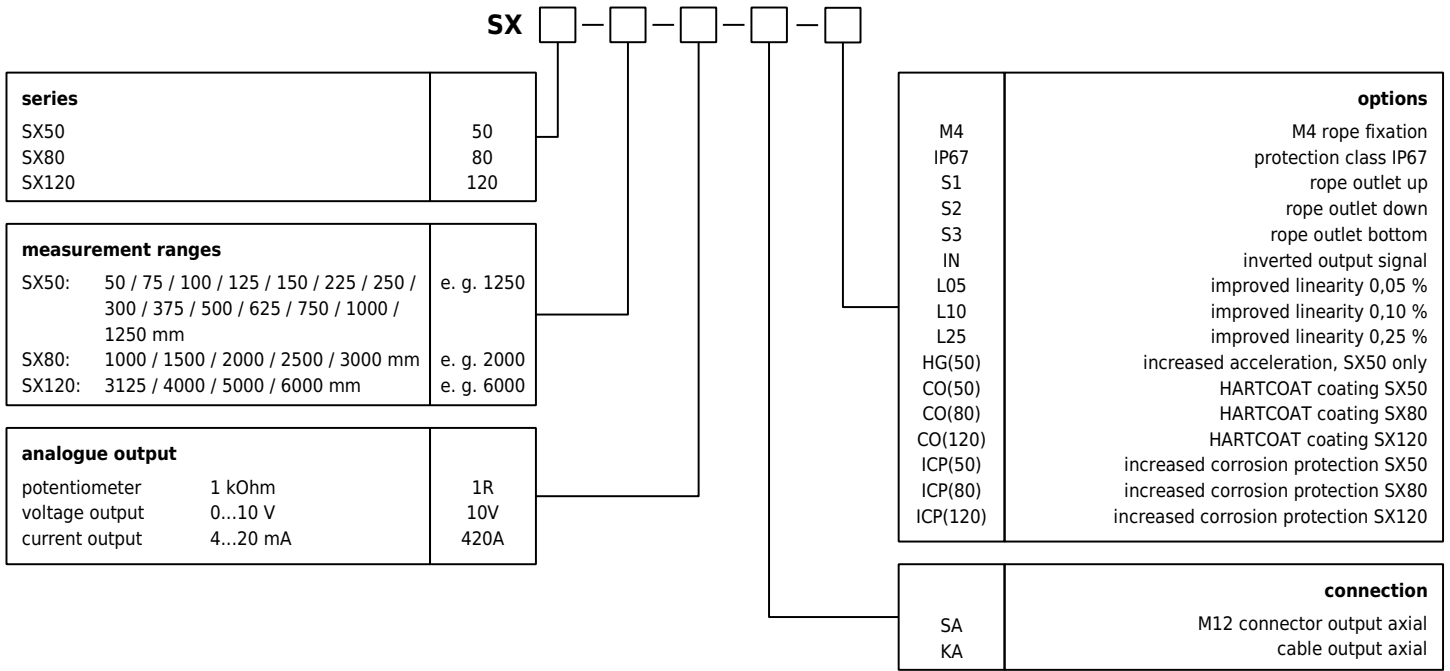

ORDER CODE DIGITAL / DIGITAL-ABSOLUTE / BUS SYSTEMS

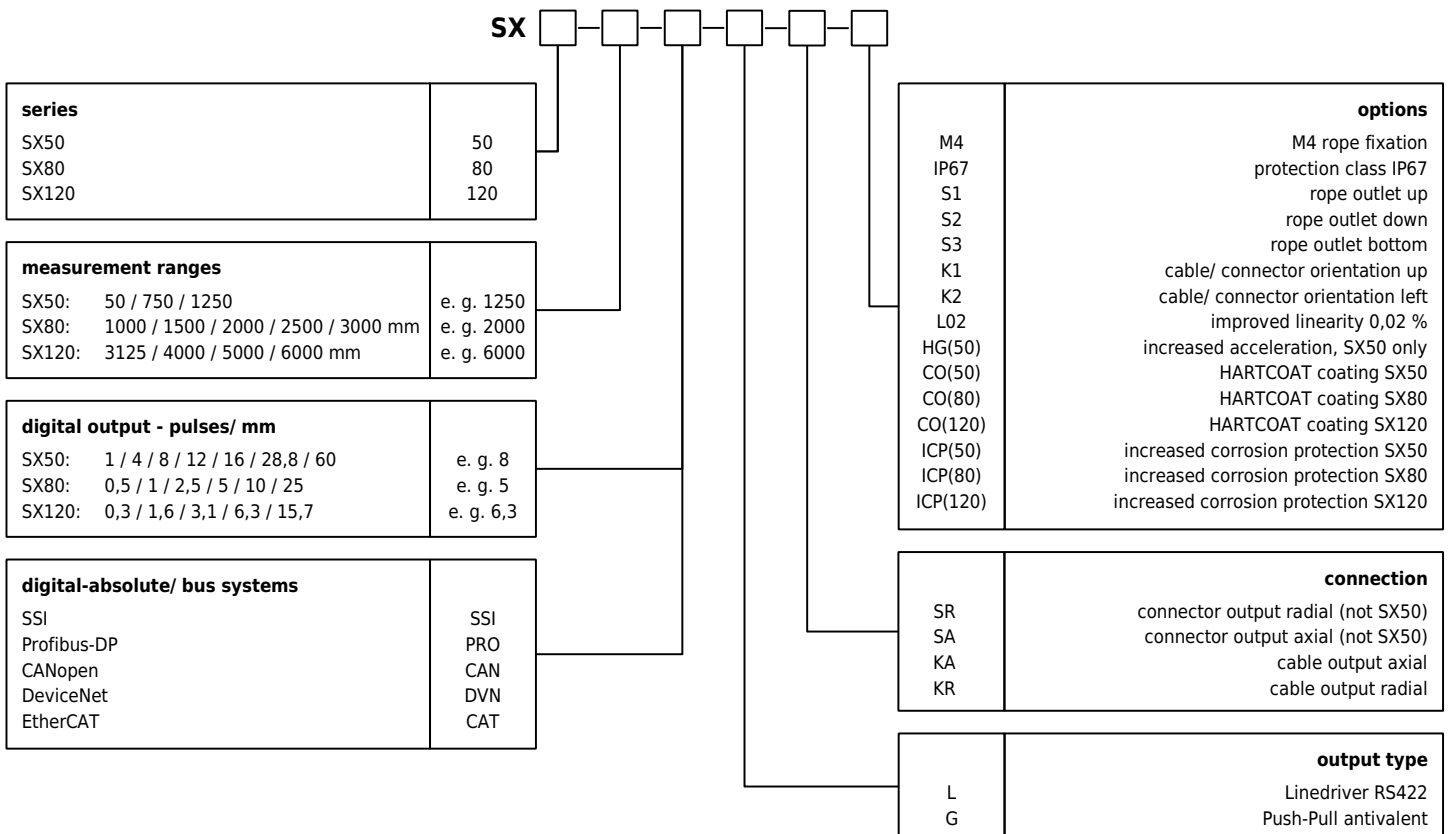

We reserve the right to alter the specification without prior notice.

WayCon Positionsmesstechnik GmbH
 email: info@waycon.de
 internet: www.waycon.de

Head Office
 Mehlbeerenstr. 4
 82024 Taufkirchen
 Tel. +49 (0)89 67 97 13-0
 Fax +49 (0)89 67 97 13-250

Office U.S.A.
 Daytronic Corporation
 Miamisburg, Ohio 45342
 Tel. 937-866-3300
 E-mail sales@daytronic.com